

Yaroslavl Spring School of Scottish Dancing 2016

Social Dancing

1 THE AMBASSADORS' REEL R32 · 3/4L

Susi Mayr: Vienna Book of Scottish Country Dances · Crib: Eric Ferguson's SCD Cribbs · Diagram: Keith Rose's Diagrams

- 1- 1c dance between 2c and cast up ; ½ Fig8 down round 2c,
- 9- 1c dance down between 3c (2c up) ; cast up, ½ Fig8 down round 3c (2,1,3)
- 17- 1c turn 1cnr RH, pass Rsh, turn 2cnr RH, pass Rsh into
- 25- Circle6 and back (2,1,3)

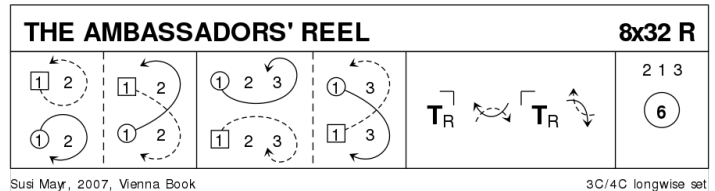

Deviser's Note: 1c can choose handing freely ; the timing is fluid, the barring only an approximation

2 THE FLYING SCOTSMAN J32 · 3/4L

Hugh A Thurston: Twelve New Scottish Country Dances (1946-1957) · Crib: Eric Ferguson's SCD Cribbs · Diagram: Keith Rose's Diagrams

- 1- 1W followed by 2W+3W cross, dance behind 1M, in front of 2M, behind 3M, cross and dance up to own places (Ladies' Train)
- 9- Men repeat (Men's Train)
- 17- 1c BHJ slip down the middle (2c up) ; and up to 2pl (2,1,3)
- 25- 2c+1c+3c (NHJ on sidelines) slip down and back

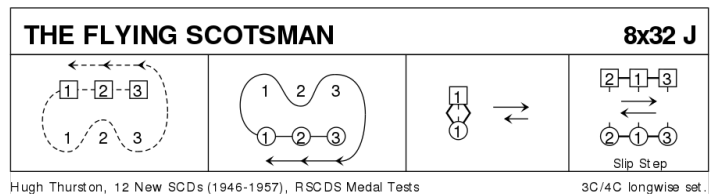

3 MARY ERSKINE R32 · 3/4L

Roy Goldring: A Second Book of Graded Scottish Country Dances · Crib: Eric Ferguson's SCD Cribbs · Diagram: Keith Rose's Diagrams

- 1- 1c (start inwards)+2c mirror turn on sides 1½ ; 1c cast behind 3c | dance up to 2pl BtoB facing own side for
- 9- DTr, but on [15-16], 1c (on opposite side) set turning right about to face P
- 17- 1c BHJ, slip down the middle & up to 2pl in the centre, facing up
- 25- 1W+2M+3M LHA while{} 1M+2W+3W RHA ; 1c ½ Fig8 up round 2c (to 2,1,3)

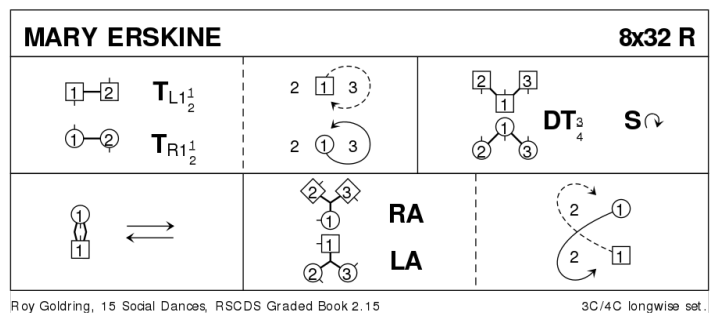

4 THE BRAES OF BREADALBANE S32 · 3/4L

Skillern: RSCDS XXI 7 · Crib: Eric Ferguson's SCD Cribbs · Diagram: Keith Rose's Diagrams

- 1- 1c Turn RH, cast off (2c up) ; turn LH, 1M/1W cast L (down/up) to between 3c/2c
- 9- Set twice in lines of 3 across ; 1c cast back and Turn RH to (2,1,3)
- 17- All set twice in sidelines ; turn partners BH
- 25- 2c+1c R&L

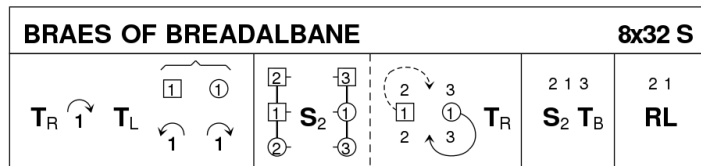

Skillern, 1795, RSCDS Book 21.7

3C/4C longwise set.

5 THE FINDLAYS' JIG J32 · 3/4L

Roy Goldring: 14 Social Dances for 2000 · Crib: Eric Ferguson's SCD Cribbs · Diagram: Keith Rose's Diagrams

- 1- 1c lead down the middle and up, 2c+3c step in for
- 9- 1c+2c+3c Allemande (to 3,2,1)
- 17- 1c long cast to 1pl (3c+2c down) ; 2c repeat (1c+3c down) (2,1,3)
- 25- Circle6 and back

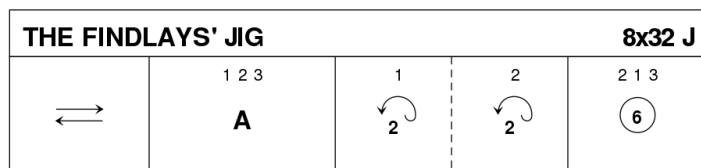

R Goldring, 2000, 14 Social Dances for 2000

3C/4C longwise set

6 ST ANDREW'S OF BRAMPTON R32 · 4/4L

Ann Campbell: RSCDS XXXVII 5 · Crib: Eric Ferguson's SCD Cribbs · Diagram: Keith Rose's Diagrams

- 1- 1c+4c cross RH, cast to middle (2c+3c to ends) ; 1c+4c RHA
- 9- 1c+4c Pick up cnrs LH and continue double wheel half round ; set to cnrs, change place with cnr LH
- 17- 2c+3c (middles) pick up new cnrs for 1/2 RHA in double wheel ; set to cnrs and change place using sideline hand to finish in end places with 1c+4c in the middle NHJ facing ends
- 25- 1c+4c dance through ends, cast to middle ; 1/2 R&L (2,4,1,3)

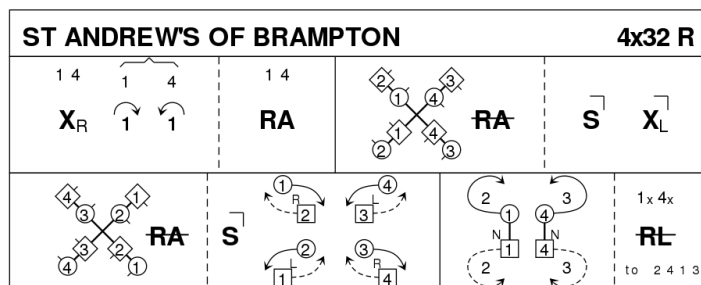

Ann Campbell, RSCDS Book 37.5

4C/4C longwise set.

note: the set keeps a longwise shape

7 MARGARET BROWN'S STRATHSPEY S32 · 3/4L

Anne Thorn: The Magic of Music · Crib: MiniCribbs

- 1-8 1s cross RH, cast 1 place, dance 1/2 Fig of 8 round 2s & end facing 1st corner
- 9-16 1s dance Pass+Turn with 1st corners & pass RSh to face 2nd corners, dance Pass+Turn with 2nd corners & end BtoB facing 3rd corners
- 17-24 1s dance 1/2 Diag reel of 4 with 3rd corners, pass RSh & dance 1/2 reel with 4th corners & end 2nd place opposite sides
- 25-32 3s+1s+2s dance Set+Link for 3 twice

8 ST ANDREW'S FAIR J32 · 3/4L

Roy Goldring: Five Scottish Country Dances 1982 · Crib: Eric Ferguson's SCD Cribbs · Diagram: Keith Rose's Diagrams

- 1- 1c cross RH | cast off 2 (2c up) ; cross LH and cast up (2,1,3)
- 9- All turn RH ½ | retain hold & set ; all chase clw to own sides (3,1,2)
- 17- 3c+1c+2c Circle6 and back
- 25- All turn LH ½ | retain hold & set ; all chase cclw to (2,1,3)

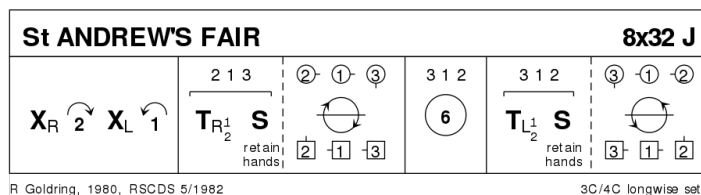

9 ORIEL STRATHSPEY S32 · 4/4L

Ian Simmonds: RSCDS XXXII 2 · Crib: Eric Ferguson's SCD Cribbs · Diagram: Keith Rose's Diagrams

- 1- All set to P | 1c+4c turn RH ½ into the middle facing down/up **while**{2} 2c+3c cross RH ; 1c+4c advance NHJ, meet dancer opposite and dance NHJ out the side and cast to own end (1x,2x,3x,4x)
- 9- All set to P | 1c+4c cross RH **while**{2} 2c+3c turn RH ½ into the middle facing own end ; 2c+3c dance out the end and cast to own places (1,2,3,4)
- 17- 1c+2c & 3c+4c RHA, LHA
- 25- 1c+4c cross diagonally to middle of set, using EH (1c RH, 4c LH) | 1c+4c circle4 L | continue circle ½ opening for 1W to lead 4W down the W side **while**{2} 4M leads 1M up the M side (2c+3c up) (to 2,3,4,1)

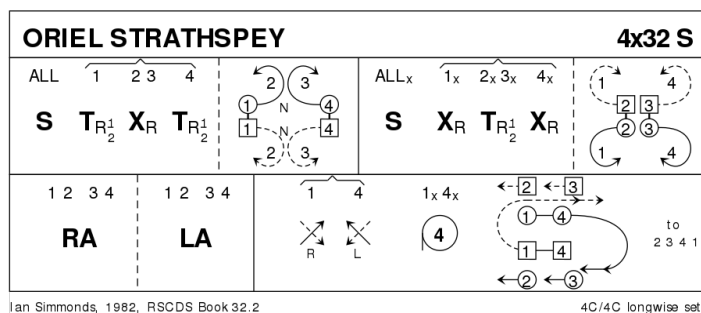

10 THE WHISTLING WIND R32 · 3/4L

Elizabeth Goosen: RSCDS XXXVI 5 · Crib: Eric Ferguson's SCD Cribbs · Diagram: Keith Rose's Diagrams

- 1- 1c set | long cast to 2pl (2c up on [5-6]) | set advancing to 1cnrs
- 9- 1c ½Reel4 with 1cnrs, pass Rsh ; 1c ½Reel4 with 2cnrs finishing BtoB in the middle, 1M facing up, 1W down
- 17- DTr up / down, finish 2pl own side (3x,1,2x)
- 25- diagonal R&L (M down, W up) (2,1,3)

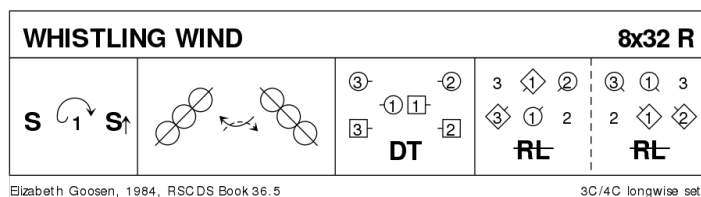

11 SPIFFIN' J32 · 5S

Quarries and Friends: Chicago 25th Anniversary Collection · Crib: Eric Ferguson's SCD Cribs · Diagram: Keith Rose's Diagrams

5c (dancing couple) stands facing 1c in centre of square set, numbered clw as usual.

- 1- 5c parallel Lsh Reels3 with 1c+3c
- 9- 5M+4c LHA **while** 5W+2c RHA ; 5c (NHJ) between 1c, divide, 5M(5W) casting left(right) round 1W(1M) back into the centre for
- 17- 5M+4c RHA **while** 5W+2c LHA ; 5c (NHJ) between 3c, divide, and cast back round 3M(3W), into the centre
- 25- 5c with RH elbow-grip make any (eg. tulloch) turn {4} ; 5c+1c set, ½ LHA to finish with 5c in 1pl and 1c in the middle facing 2c (i.e. next couple clw) to start again.

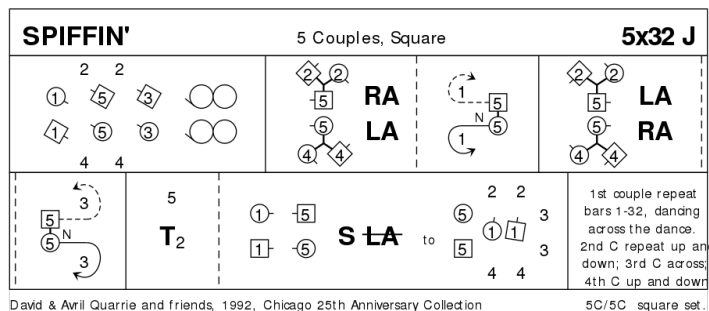

after 5 times through, 5c finish in the middle, all other C one place clw

12 GLENGRANT S32 · 2/4L

Hugh Foss: Glendarroch Scottish Dance Sheets · Crib: MiniCribs

- 1-8 1s set advancing & turn 2H, lead down crossing & cast up to 1st place opposite sides
- 9-16 1s+2s dance 3/4 R&L & Adv+Ret (up/down) for 1 step
- 17-24 2s+1s set advancing to partner & turn 2H, 1s cast up & dance down to 2nd place **while** 2s cross down & cast up to top
- 25-32 2s+1s dance 3/4 R&L & circle left 1/2 way

13 DONNA'S DIAMONDS R32 · 2/4L

Sheila Gradon: Beyond The Black Stump and Fifteen Other SCD · Crib: SCDDDB Contributed Cribs & Diagrams

- 1-16 1st couple dance a Petronella Diamond.
- 17-18 1M and 2L change places giving right hands.
- 19-20 1L and 2M change places giving right hands.
- 21-22 1M and 3M change places giving left hands.
- 23-24 1L and 3L change places giving left hands.
- 25-26 1M and 4L change places giving right hands.
- 27-28 1L and 4M change places giving right hands.
- 29-32 All tum right hands 1½ times to own side.

Repeat with a new top couple

14 C'EST L'AMOUR J32 · 3/4L

RSCDS: RSCDS XXXIV 1 · Crib: Eric Ferguson's SCD Cribs · Diagram: Keith Rose's Diagrams

- 1- 1W casts off one (2W up) | set to 2M ; repeat with 3M (3W up)
- 9- 1W (1M) cast up (down) to 2pl (3W & 2M step down/up), 1c set ; 1W (1M) casts up (down) to midline in 1pl (3pl) facing P | 1c set (2c & 3c step towards each other on sidelines)
- 17- 1W+2c & 1M+3c circle3 & back, 2c & 3c finish BtoB facing ends, NHJ
- 25- All set | 2c+3c dance to ends making arches as 1W & 1M dance under arches to 2pl ; 2c+1c+3c turn RH (2,1,3)

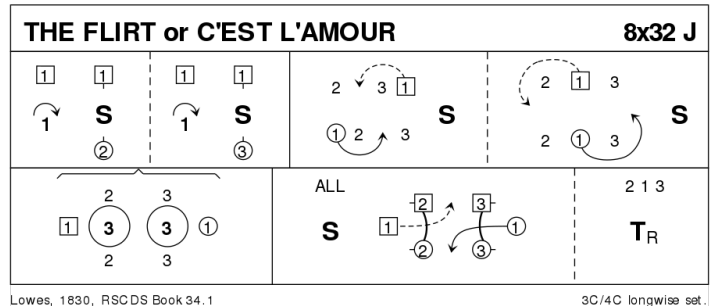

15 THE TRIUMPH R24 · 4/4L

Nathaniel Gow: RSCDS I 2 · Crib: Eric Ferguson's SCD Cribs · Diagram: Keith Rose's Diagrams

- 1- 1c lead down the middle and up, 1M presents 1W to 2M
- 9- 1W+2M (NHJ), followed by 1M, dance down the middle ; 1W+2M turn inwards and 1M joins (1W hands crossed and joined to outer hands of 1M+2M, their NH making arch above 1W), all three dance up in TRIUMPH to finish 2M in own place and 1c BHJ on opposite sides
- 17- 1c Poussette down the middle to bottom pl (¼ R turn, progress, ¼ turn, ¼ turn, progress, progress with ¼ turn, ½ turn to own side, fall back to sides), (all other couples step up on 23-24).

