

# Kazan 2017 - Dances taught by Malcolm Brown

## 1 GLEN MOR J32 · 3/4L

*Eric Forbes: Birmingham Book 2004 - Twenty Scottish Country Dances (Compilation of 1973 and 1986) · Crib: MiniCribs · Diagram: Keith Rose's Diagrams*

- 1-8** 1s+2s set, dance 1/2 RH across, 1s+3s set, dance 1/2 LH across
- 9-16** 1s set & cast up 1 place as 3s stand & cross back to places, 1s set & cast up 1 place as 2s stand & cross back to places
- 17-24** All dance reels of 3 on own sides (2s dancing out round 3s to start)
- 25-32** 1s+2s 3/4 turn RH, 1M+2L turn LH 1.1/2 times **while** 1L & 2M chase clockwise to meet partner & 3/4 turn partners RH to places

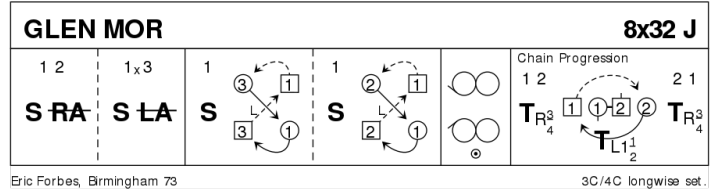

## 2 THE RUTLAND REEL R40 · 3/4L

*Robert Senior: RSCDS XLVIII 2 · Crib: MiniCribs · Diagram: Keith Rose's Diagrams*

- 1-8** 1s set & cast 1 place, 1s cross between 3s & cast up to 2nd place opposite sides
- 9-16** 1s+2s dance Ladies Chain & end 1s facing down
- 17-24** Reel of 3 on sides, 1s giving RSh to 3s & 1s+3s 1/2 turn RH 2 3(1)
- 25-32** 3s+1s dance Mens Chain & end 1L facing out with partner ready to follow her
- 33-40** 1L followed by partner casts up & crosses to own side to end 1s in 2nd place own sides, 1s+3s circle 4H round to left

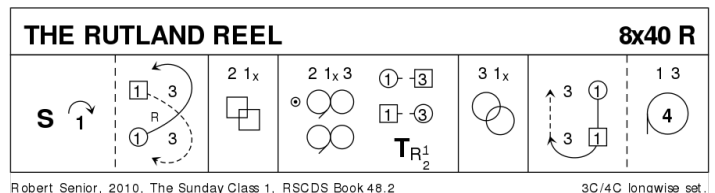

## 3 THE SYLVAN STRATHSPEY S32 · 3/4L

*Tom Winter: Dunsmuir Dances · Crib: MiniCribs*

- 1-8** 1s set, cross RH, 1s+2s Set+Link
- 9-12** 2s+1s circle 4H round to left 1/2 way, Men turn Ladies 2H into diagonal line between 1M & 2L positions (Ladies BtoB)
- 13-16** 1s+2s dance 1/2 diagonal reel of 4 with 1L ending in original place & 2L in partners original place (2s on Men's side)
- 17-24** 1s+2s dance R&L
- 25-32** 1s+2s dance the Tournee :  
1s+2s dance into prom hold (Men with prtnr on right, 1s face M's side & 2s L's side), couples 1/2 wheel anticl'wise & Men turn Ladies into middle, both couples turn 1.1/2 times (2s RH, 1s LH) & dance out to places

## 4 PROGRAMME ITEM – Mainly Douglas (J32)

## 5 THE PAWLING PORCH R32 · 3/4L

Elaine Brunken: *Moments in Time* · Crib: *MiniCrib*s · Diagram: *Keith Rose's Diagrams*

- 1-8 1s set, cast to 2nd place (2s step up), dance down between 3s & cast up to 2nd place
- 9-16 1s with 1st corners Adv+Ret & 1s turn 1st corners RH
- 17-24 1s with 2nd corners Adv+Ret & 1s turn 2nd corners RH
- 25-32 2s+1s+3s circle 6H round & back

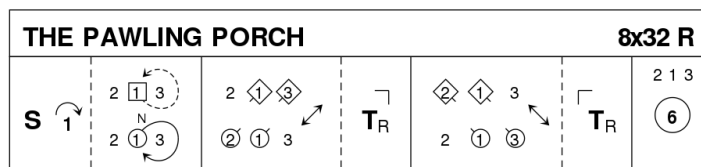

Elaine Brunken, 2005, *Moments in Time*

3C/4C longwise set.

## 6 FAR NORTH QUEENSLAND S32 · 5/5L

John Brendhley: *The Other Kangaroo Paw* · Crib: *MiniCrib*s · Diagram: *Keith Rose's Diagrams*

- 1-4 1s+ 5s cross RH & cast down/up 1 place (2s+4s step up/down)
- 5-8 1M+2s also 1L+3s+5M also 5L+4s dance circles round to Left. 1s+5s end in middle facing partners (Men facing down, Ladies facing up)
- 9-16 1s+5s set, dance 1/2 reel of 4, set advancing to partners, pass LSh to face 2nd corner positions
- 17-24 1s+5s dance 1/2 diag. reel of 4 with 2nd corners, turn LH to face 1st corner positions, dance 1/2 diag. reel of 4 with 1st corners, turn LH to face 4th corner positions (partner's 2nd corner position)
- 25-32 1s+5s dance 1/2 diag. reel of 4 with 4th corners, turn LH to face out on own sides, cast 1 place (3s+2s step up 31-32) 4 3 5 2 1

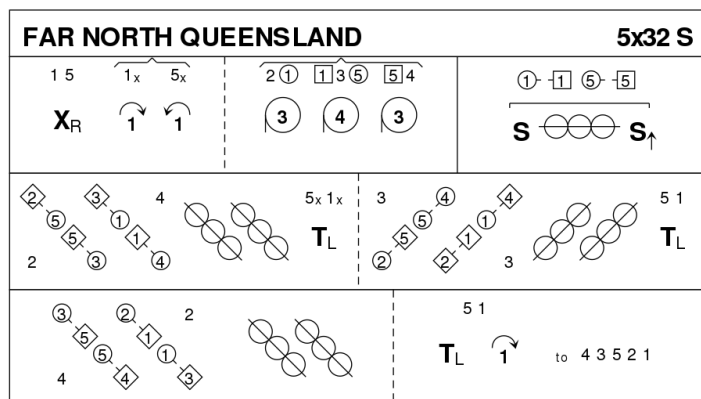

John Brendhley, 2011

The Other Kangaroo Paw, www.members.west.net.com.au/trevanne/rsdswa/theotherkangaropaw.htm

5C/5C longwise set.

## 7 THE FRIDAY CLASS S32 · 3/3L

Helen C.N. Brown: *Forty and Counting*

## 8 THE RUNES J32 · 3/4L

Barry Skelton: *The Tiki Book*

## 9 FIRST LOVE S32 · 2/4L

Frans Ligtmans: *The Thistle Club* · Crib: *Eric Ferguson's E-cribs* · Diagram: *Keith Rose's Diagrams*

- 1- 1c dance clw 1¼ round P, spiraling in, finish facing down 1M behind 1W ; 1W, with 1M following, cast up round 2M to (1,2)
- 9- 1c lead down the middle and up, facing out
- 17- 1c+2c Double Fig8, finish in the middle for
- 25- 1c+2c Allemande (2,1)

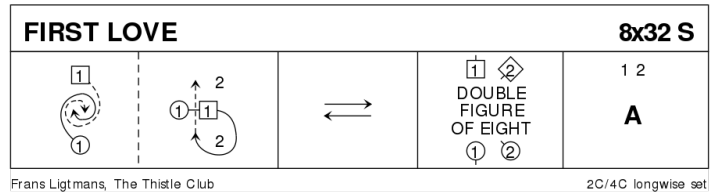

## 10 WICKED WILLY R32 · 4/4L

Harry C Ways: *Bicentennial Book plus Seven SCD* · Crib: *MiniCribs* · Diagram: *Keith Rose's Diagrams*

- 1-8 1s & 4s cross RH & cast 1 place, dance 1/2 Fig of 8 round end couples into centre facing corner just passed
- 9-16 1s & 4s dance 'Hello-Goodbye' setting to face diagonally opposite corner
- 17-24 1s & 4s turn corner person RH & dance LH across once round to end on opposite sides
- 25-32 Bottom 2 couples dance 1/2 R&L, then middle 2 couples dance 1/2 R&L

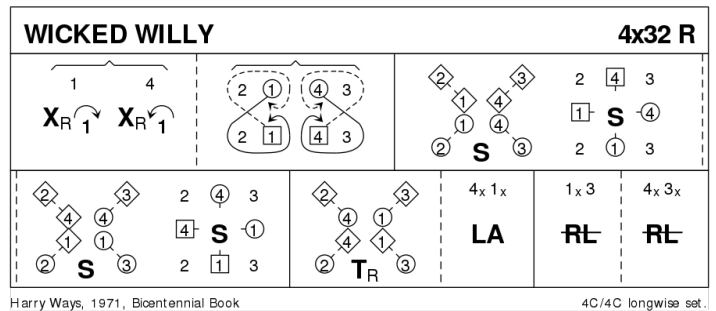

## 11 THE DUKE OF ATHOLL'S REEL J32 · 2/4L

Skilern: *RSCDS XVI 3* · Crib: *MiniCribs* · Diagram: *Keith Rose's Diagrams*

- 1-8 1s+2s set, dance 1/2 RH across, set & dance 1/2 LH across back to places
- 9-16 1M+2L set advancing & turn RH back to places, 1L+2M set advancing & turn RH back to places
- 17-24 1s cross RH, cast to 2nd place & dance 1/2 Fig of 8 round 2s to 2nd place on own sides
- 25-32 2s+1s dance R&L

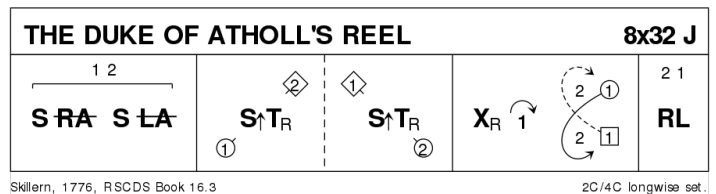

## 12 PROGRAMME ITEM – Bundle of Eights (R32)

### 13 BROADFORD BAY R32 · 3/4L

Anne Grant: *The Leaflet Dances with Music* · Crib: *MiniCrib*s · Diagram: *Keith Rose's Diagrams*

- 1-8 1s followed by 2s dance down the middle, cast up round 3s on own sides, dance in & up to top, 1s casting to 2nd place
- 9-16 2s+1s+3s dance Grand Chain (2M & 1L end facing out)
- 17-24 2L+1M turn RH 1.1/2 as 2M+1L dance 1/2 way round anticl'wise, 2L+1M dance 1/2 way round cl'wise as 2M+1L turn LH 1.1/4 times to face ptrns
- 25-32 2s+1s (facing partners) dance diagonal reel of 4 ending on own sides with 1s in 2nd place

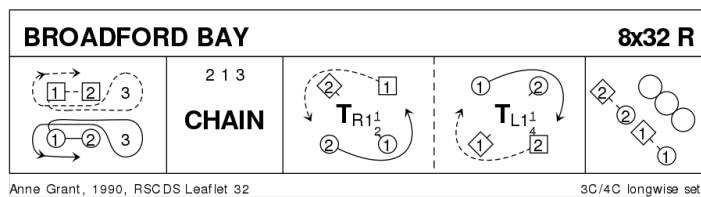

### 14 SANDY O'ER THE LEA S32 · 2/4L

Miss Milligan's *Miscellany of Scottish Country Dances* · Crib: *MiniCrib*s · Diagram: *Keith Rose's Diagrams*

- 1-8 1s+2s dance RH across & LH back to places
- 9-16 1s+2s set; cross RH, set & cross back RH
- 17-24 1s followed by 2s lead down, 2s divide & 1s followed by 2s lead back to top
- 25-32 1s+2s dance Allemande

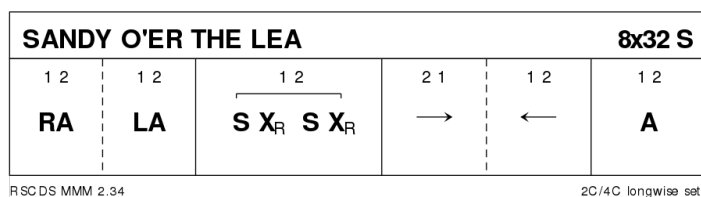

### 15 MAY THE 4TH BE WITH YOU R32 · 3/4L

Antoine Rousseau: *The Paris Book of Scottish Country Dances, vol. 1* · Crib: *Eric Ferguson's E-cribs* · Diagram: *Keith Rose's Diagrams*

- 1-- 1c+2c Circle4 L ; RHA
- 9-- 1c set | cast (2c up) ; set to P | set advancing and pivot R to DTr position
- 17-- 2c+1c+3c DTr (2,1,3)
- 25-- 1c+3c LHA ; Circle 4 R *On first time through, 1c+3c hold on to hands on [32] to enter Circle4 L. When new top starts, the bottom couples may dance [1-12] to change places.*

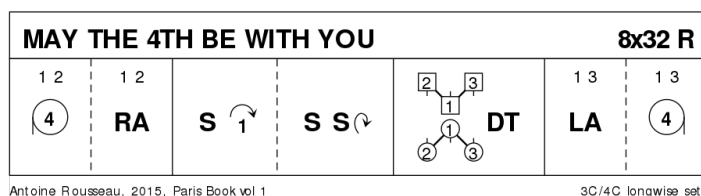

### 16 TRAVELLING TRIANGLES R40 · 3/4L

Harry Robertson: *Melbourne Dance Book* · Crib: *MiniCrib*s

- 1-8 1s cross RH, cast 1 place & dance 1/2 Fig of 8 round 2s
- 9-16 2s+1s+3s dance DoSiDo & turn RH into prom hold
- 17-24 2s+1s+3s dance Allemande 1s ending facing opposite as for double triangles
- 25-32 All set, 1s 1/2 turn 1st corner RH into centre, all set, 1st corner persons 1/2 turn 2nd corners RH into centre
- 33-40 All set, 2nd corner person 1/2 turn 1s into centre, all set & 1s dance round each other RSh to 2nd place own side

## 17 MISS JOHNSTONE OF ARDROSSAN R32 · 5/5L

Roy Goldring: 14 Social Dances for 2000 · Crib: MiniCribS · Diagram: Keith Rose's Diagrams

- 1-8** 1s set & cast 1 place, 1s followed by 3s dance up & cast - 1s to 3rd place & 3s to 2nd place
- 9-16** 1s cross down & dance reflection reels of 3 with 4s+5s on opposite sides - 1s end in 3rd place opposite sides
- 17-24** 1s cross up & dance reflection reels of 3 on own sides with 2s+3s - 1s ending in 3rd place own sides
- 25-32** 1s set & cast down 1 place, 1s followed by 5s dance up between 4s & cast - 1s to 5th place & 5s to 4th place

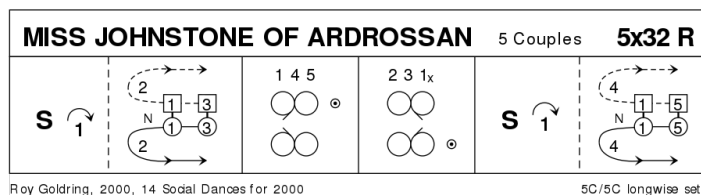

## 18 BARBARA'S LITTLEBECK SCRAMBLE S32 · 5/5L

Source unknown · Crib: MiniCribS · Diagram: Keith Rose's Diagrams

- 1-8** All set, turn partner 2H twice round & all set
- 9-16** 2s & 4s dance RH across (L up & M down to give wheels of 3, 4 & 3), 2s & 4s change wheels for LH back
- 17-24** 1s dance Fig of 8 round 2s **while** 3s dance round 4s, 1s+2s also 3s+4s end ready for Poussette
- 25-32** 1s+2s also 3s+4s dance 1/2 Diamond Poussette, 1s+4s also 3s+5s dance 1/2 Poussette. 2 4 1 5 3

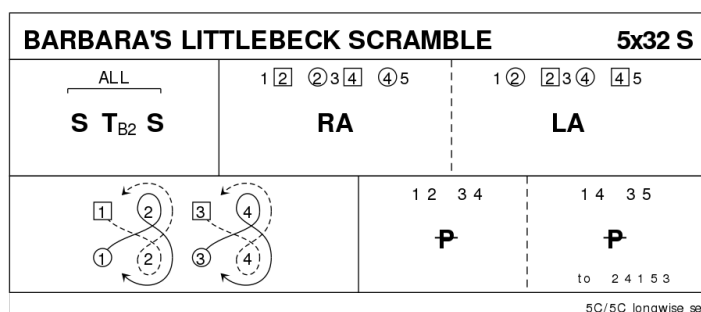

## 19 PROGRAMME ITEM – As Good As Ever (R32)

## 20 THE ENTWIVES S32 · 5/5L

Peggy Hamilton: The Middle Earth Collection

## 21 MACLEOD'S FANCY J32 · 4/4L

John Drewry: RSCDS XXXIII 3 · Crib: MiniCribbs · Diagram: Keith Rose's Diagrams

- 1-8** 1s+4s set diagonally, 1M+4L 3/4 turn RH & cast up/down own side back to place **while** 1L+4M cast down/up own side & 3/4 turn RH back to place
- 9-16** All dance reels of 4 on sides, ending as at start of reel
- 17-24** 2s & 3s turn 1s & 4s RH into a St Andrew's Cross, all set & turn cmrns to end 1s in 3rd pl & 4s in 2nd pl on own sides having passed other cmr RSh
- 25-32** 1s & 4s set & cross over (Ladies dancing between Men) & dance 1/2 Fig of 8 round end couples to 3rd/2nd places (giving RH at top, LH at bottom)

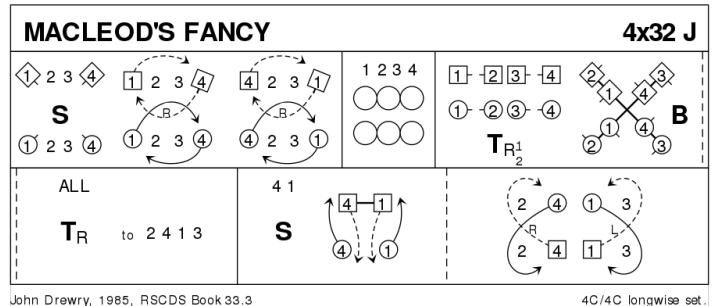

## 22 ONE SET SHORT OF A HUNDRED S32 · 3/3L

Aliénor Latour: The Paris Book of Scottish Country Dances, vol. 1 · Crib: Eric Ferguson's E-cribs · Diagram: Keith Rose's Diagrams

- 1--** 1c+2c Pousette
- 9--** 1c lead down {3}, up {3} and cast to 2pl (2c up) (2,1,3)
- 17--** 1c+3c Tourbillon
- 25--** Circle6 and back (2,3,1)

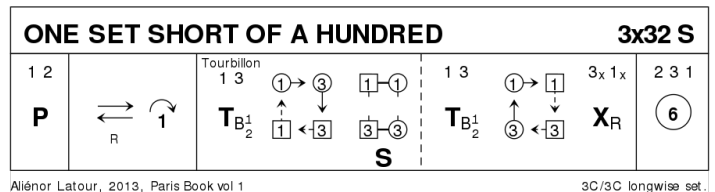

## 23 MUIRLAND WILLIE J32 · 3/4L

RSCDS XXI 9 · Crib: MiniCribbs · Diagram: Keith Rose's Diagrams

- 1-4** 1s lead down middle & cross over to cast up to 2nd pl **while** 2s set & cross RH to 3rd pl **while** 3s cast up to 1st place & cross RH
- 5-8** All set & 1/2 turn 2H to own side
- 9-16** Repeat bars 1- 8 from new pstns
- 17-24** 1s lead up to 1st place & set, 1s+2s set advancing
- 25-32** 1s+2s dance Pousette. 2 1 3

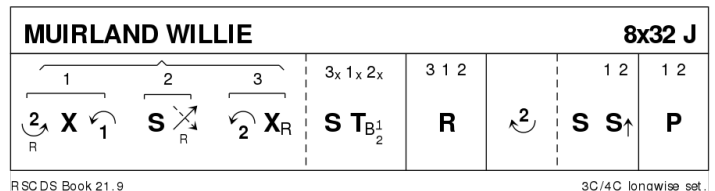

## 24 DUMBARTON DRUMS R32 · 3/4L

Thomas (19C) Wilson: RSCDS V 2 · Crib: MiniCribbs · Diagram: Keith Rose's Diagrams

- 1-8** 1s dance RSh reels on own sides
- 9-16** 1s lead down the middle & back to top
- 17-24** 1s+2s dance Allemande 1s end with Lady between 2s facing down & Man between 3s facing up
- 25-32** All set twice 1s turning to left to 2nd place own sides (reverse petronella turn), all set twice

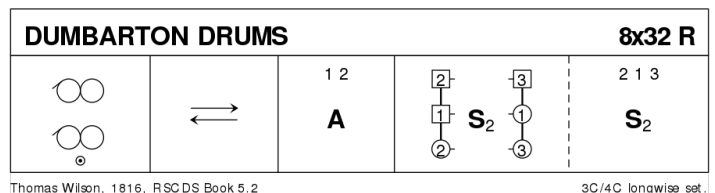

## 25 ANN LINDSEY'S STRATHSPEY

S32 · 3/4L

Charles T Snowdon · Crib: MiniCribs · Diagram: Keith Rose's Diagrams

- 1-8** 1s+2s set advancing & dance RSh round partner 1.1/2 times spiralling out to opposite sides & circle left 4H round 1/2 way
- 9-16** 1s+3s repeat above figure
- 17-24** 1s lead up between 3s & out behind 2s to top, 1s turn 2H
- 25-32** 1s+2s dance the Knot:

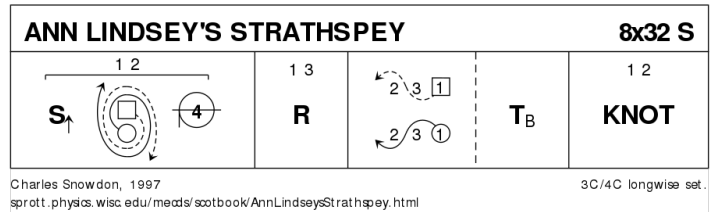

## 26 PROGRAMME ITEM – Congratulations (J32)

## 27 THE YOUNG PRETENDER

J32 · 6/6L

Barry Priddey: Fairy Bridge Book · Crib: MiniCribs

- 1-8** 1s+4s also 3s+6s set facing in diagonally, 1M+4L also 3M+6L 3/4 turn RH, 1M & 4L dance out thru 4M/6M places as 1L & 4L dance out thru 4L/6L places & cast back to place **while** 1L & 3L cast to 4L/6L places as 4M & 6M cast up to 1M/3M places & 4M+1L also 6M+4L 3/4 turn RH (similar to MacLeod's Fancy)
- 9-16** 1s+2s+3s also 4s+5s+6s dance reels of 3 on sides (1s+2s also 5s+6s pass RSh to start)
- 17-24** 1s+2s also 3s+4s also 5s+6s dance reels of 4 across (1M+2L, 3M+4L & 5M+6L pass LSh to start) & 1L+2M, 3L+4M & 5L+6M omit last LSh pass to all end in original places
- 25-32** 1s+2s & 3s+4s & 5s+6s dance RH across 1/2 way, set & 2s & 5s (now end couples) cross LH **while** 1s+4s & 3s+6s dance LH across 1/2 way & all set

## 28 GANG THE SAME GATE

S32 · 3/4L

Milton Levy: RSCDS XXXVI 4 · Crib: MiniCribs · Diagram: Keith Rose's Diagrams

- 1-8** 1s cross RH & cast down to 3rd place, cross RH & cast up to 2nd place on own sides
- 9-16** 1s set adv to ptrn & turn 1st crnr 2H to face 2nd crnr, 1s dance 1/2 reel of 4 ending M b'tw'n top cpl facing down & L b'tw'n bottom cpl facing up
- 17-24** 1s set adv to partner & turn 4th corner (pstrn) 2H to face own 1st corner (pstrn), 1s dance 1/2 diagonal reel with 1st corners ending in 2nd place opp sides
- 25-32** 3s+1s+2s Set+Link for 3 twice

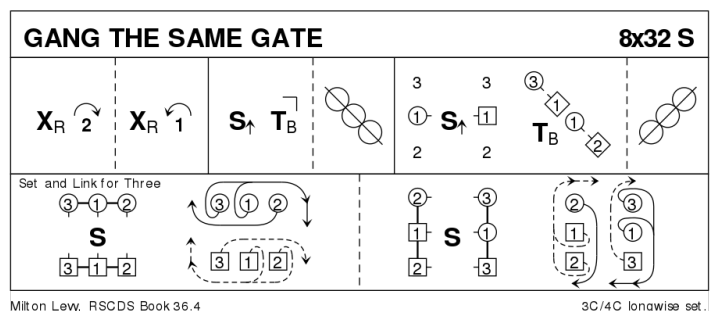

## 29 JOHNNIE WALKER M128 · 4S

Norman & Helen Robson: *The Whisky Collection* · Crib: *MiniCribs* · Diagram: *Keith Rose's Diagrams*

- 1-8** All circle 8H round & back  
**9-16** All set to corners & turn RH, set to partners & turn LH  
**17-24** 1s & 3s advance to centre & lead out through sides with opposite partner, cross & dance to opposite sides & turn partner RH 1.1/2 times  
**25-32** 2s & 4s repeat 17-24  
**33-40** All Ladies petronella one place to right & all set, Ladies petronella on to next place to right & set  
**41-48** All Men petronella one place to right & all set, Men petronella on to next place to right & set  
**49-64** All dance Grand Chain once round & dance Allemande anticlockwise  
**65-128** Repeat in Jig time

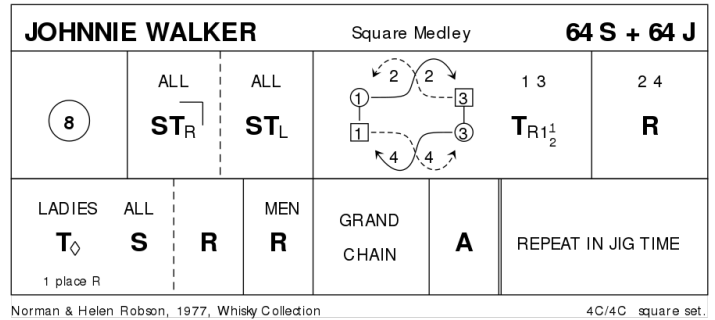

## 30 THE FINAL REEL R32 · 3/4L

Ian Barbour · Crib: *MiniCribs* · Diagram: *Keith Rose's Diagrams*

- 1-8** 1s cross RH, cast 1 place & turn LH 1.1/4 times to end 1M between 2s & 1L between 3s  
**9-16** 2s+1s+3s Set+Link for 3 twice 1s end facing 1st corners pstns  
**17-24** 1s dance 1/2 reel with 1st corners & 1/2 reel with 2nd corners, 1s ending in 2nd place own sides  
**25-32** 2s+1s+3s circle 6H round & back

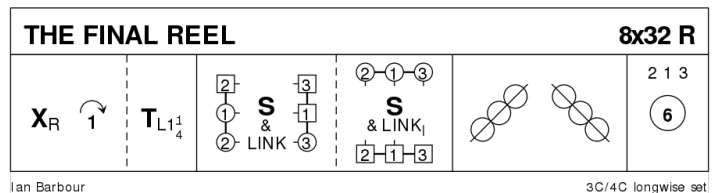

## 31 PROGRAMME ITEM – November Ceilidh (R/J32)

## 32 PROGRAMME ITEM – Lucky Seven (R/J32)

## 33 GIBSON'S GALLOP R32 · 1RR

John Drewry: *The Welsh Set* · Crib: *Eric Ferguson's E-cribs*

*Couples with W on the R, face cclw in circle RR*

- 1--** All couples, NHJ, dance RR cclw, pivot inwards ; All couples dance clw, finish facing cclw  
**9--** All W dance Rsh round M in front of her P and Lsh round P, to places  
**17--** All M dance Lsh round W in front of his P and Rsh round P, to places  
**25--** All couples BHJ slip cclw ; slip clw {2} | All retire with clap, and advance to next person to the R