

2017 Spring School Social Dancing

1 COME UNDER MY PLAIDIE J32 · 2RR

Six Scottish Dances (YSDA 1) · Crib: MiniCribs · Diagram: Keith Rose's Diagrams

Round the Room Dance 2 facing 2

- 1-8 All turn opposite partner RH, all turn own partner LH into prom hold (Men on inside facing anticlockwise)
- 9-16 Both couples Promenade LSh round each other to original places
- 17-24 Both couples dance Ladies Chain
- 25-32 All Adv+Ret, all advance 3 steps passing opposite partner by RSh & retire 1 step

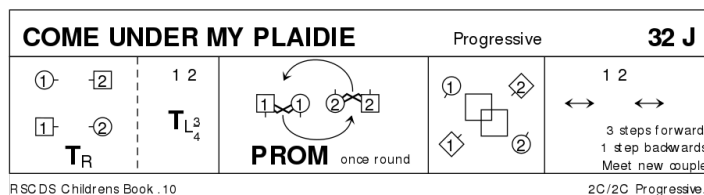

2 THE WESTMINSTER REEL R32 · 2/4L

Jeremy Hill: RSCDS XLV 1 · Crib: MiniCribs · Diagram: Keith Rose's Diagrams

- 1-8 1M+2L turn RH, 1L+2M turn RH 1.1/2 times end facing partner ready for diagonal reel of 4
- 9-16 1s+2s dance diagonal reel of 4
- 17-24 1s+2s Set & Rotate :
Set, rotate singly & dance on 1 place clockwise, change places RH on sides & dance on 1 place to own sides (1s in 2nd pl)
- 25-32 2s+1s dance R&L

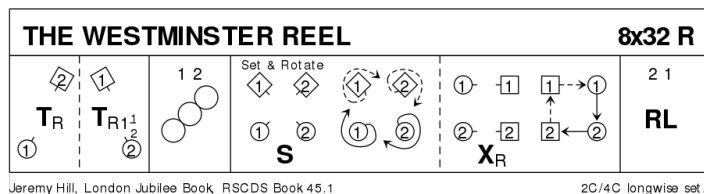

3 MISS GIBSON'S STRATHSPEY S32 · 3/4L

Derek Haynes: The Leaflet Dances with Music · Crib: MiniCribs · Diagram: Keith Rose's Diagrams

- 1-8 1s+2s set, turn partners 2H opening out into 4H round
- 9-16 1s+2s dance the Knot, 1s turn LH to end facing 1st corners
- 17-24 1s turn corners RH, partners LH, 2nd corners RH & partners LH finishing in middle facing opp sides
- 25-32 1s dance RH across, (1M with 3s & 1L with 2s), pass partner RSh & dance LH across with other couple, 1s end in 2nd place

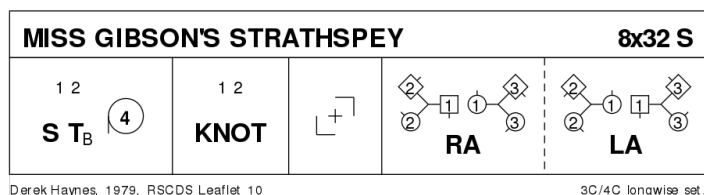

4 POSTIE'S JIG J32 · 4/4L

Roy Clowes: Commonwealth Ceilidh Dances · Crib: MiniCribs · Diagram: Keith Rose's Diagrams

- 1-8 1s & 4s set & cast in 1 place, 1s & 4s dance 1/2 Figs of 8 round new end couples
- 9-12 1M+4M & 1L+4L cross (men making an arch) & turn corners with free hand to face up/down
- 13-16 1s+4s dance down/up (couple dancing up make the arch) & turn corners
- 17-24 Repeat bars 9-16 from new pstns
- 25-32 1s+4s dance 1/2 R&L, turn partner RH

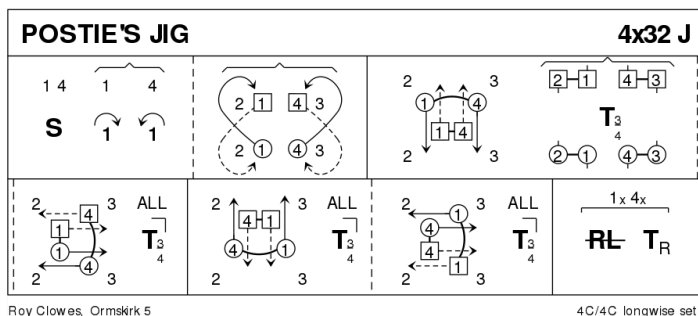

5 ADVANCE BUT NO RETIRE R32 · 3/4L

Geraldine & Holger Schuckelt: Riverside Dances · Diagram: Keith Rose's Diagrams

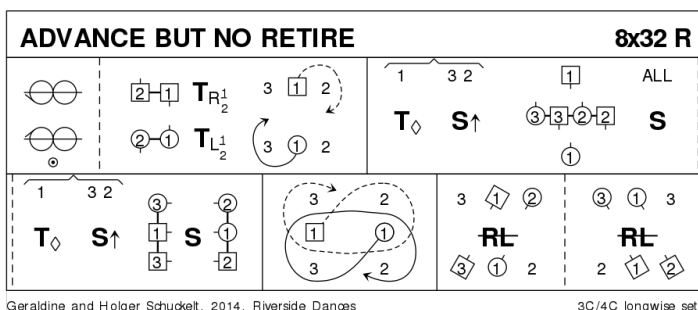

6 THE WILD MOUNTAIN THYME S32 · 3T

Pat Paterson: Southsea Celebrates 50 Years of Scottish Country Dancing · Crib: MiniCribs · Diagram: Keith Rose's Diagrams

- 1-8 All facing partners set & turn RH. Men dance LH across in centre
- 9-16 All facing partners set & turn LH. Ladies dance RH across in centre
- 17-20 All pass partner RSh, pass next person LSh, turn next person 2H once round
- 21-24 Repeat bars 17-20. This gives the progression as each Lady is now dancing with a new Man. (1L with 2M, 2L with 3M, 3L with 1M)
- 25-32 All set in circle, circle 6H round for 2 bars, dance into centre on next bar, pull RSh back and spiral out, dance round following each other into place

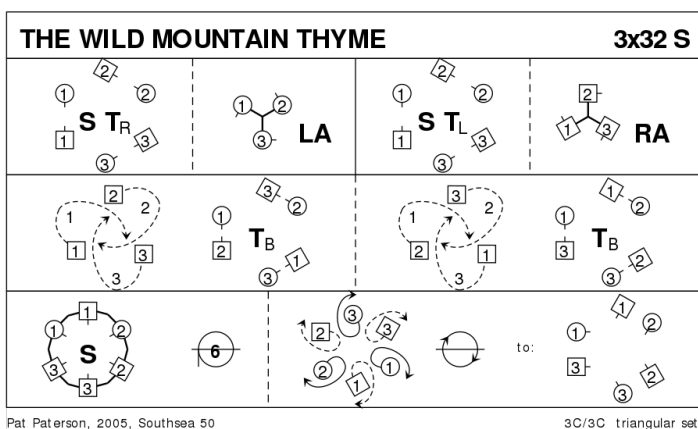

(Men return to original places, Ladies have progressed)

7 THE CRANBERRY TART J32 · 3/4L

Terry Glasspool: Dances from the Seven Year Itch · Crib: MiniCribs · Diagram: Keith Rose's Diagrams

- 1-8** 1M sets & casts 1 place, sets & petronella turns between 3s facing up **while** 1L stands for 2 bars then sets, casts 1 place & sets
- 9-16** 1M sets in line with 3s & all 3 Adv+Ret then 1M advances to partner **while** 1L petronella turns between 2s & sets in line with 2s then all 3 Adv+Ret
- 17-24** 1L followed by partner dances reel of 3 across with 2s (RSh to 2L) to end in 2nd place own sides
- 25-32** 1s dance RSh reels of 3 on sides giving RSh to 3s

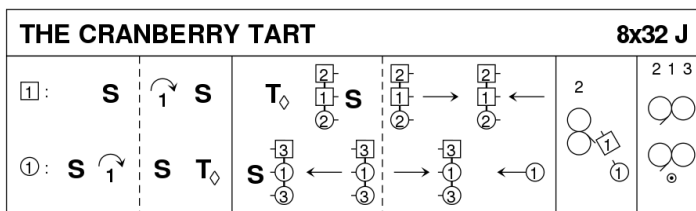

Terry Glasspool, 7 Year Itch

3C/4C longwise set.

8 THE BLACK MOUNTAIN REEL R32 · 5/5L

Derek Haynes: Carnforth Collection of SC Dances 3 · Crib: MiniCribs · Diagram: Keith Rose's Diagrams

- 1-8** 1s & 3s cross RH & cast down 1 place, dance 1/2 Fig of 8 round the couples above them & cross to face 1st corners
- 9-16** 1s & 3s turn 1st corners RH & partner LH, turn 2nd corner RH & partner LH to face 1st corners again
- 17-24** 1s & 3s dance diagonal reels of 4 with 1st corners
- 25-32** All dance RH across once round (1L with 2s, 1M+3L with 4s & 3M with 5s), 1s & 3s turn ptrns LH & cast one place

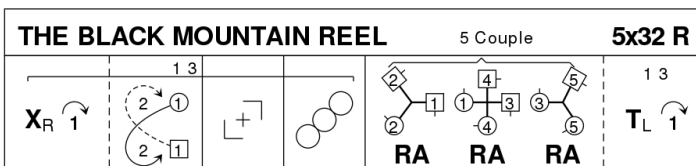

Derek Haynes, 1968, Carnforth Collection 3

5C/5C longwise set.

9 MOMENT OF TRUTH S32 · 3/4L

Claudette Sigg: RSCDS XXXVII 2 · Crib: MiniCribs · Diagram: Keith Rose's Diagrams

- 1-8** 1s turn 2H, cast to 2nd place, dance down between 3s, cast up 1 place on own sides & dance in to face 1st corners
- 9-16** 1s turn 1st corner RH, partner LH, 2nd corner RH, partner LH end facing 1st corners
- 17-24** 1s dance reels of 3 across (1L+2s & 1M+3s) giving LSh to 1st crnrs & 2s+1s+3s turn 2H
- 25-32** 1s dance Pass+Turn with 1st corners & pass RSh to face 2nd corners, dance Pass+Turn with 2nd corners & dance to places

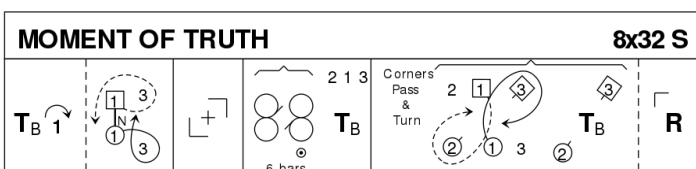

Claudette Sigg, RSCDS Book 37.2

3C/4C longwise set.

10 THE WILD GOOSE CHASE J32 · 4/4L

John Drewry: *The Brodie Book* · Crib: *MiniCribs* · Diagram: *Keith Rose's Diagrams*

- 1-8** 1L followed by 1M dances Fig of 8 on Ladies side, (in front of 2L, out round 3L, in & out behind 2L) ending in centre (opp sides) facing 4s, **while** 4s dance similarly on Men's side ending facing 1s
- 9-16** 1s+4s set facing each other **while** 2s join 1s as 3s join 4s to form lines across, all set & dance RH across with opposite 2 dancers
- 17-24** All dance full reels of 4 across dance, 1s & 4s end in centre holding RH facing opposite sides (as Wild Geese) 2s & 3s end in 1st/4th places
- 25-32** 1s+4s Bal-in-Line in centre of dance, 3/4 turn partner RH, 1s & 4s lead up to top, 1s cast to 3rd place & 4s cast to 2nd place. 2 4 1 3

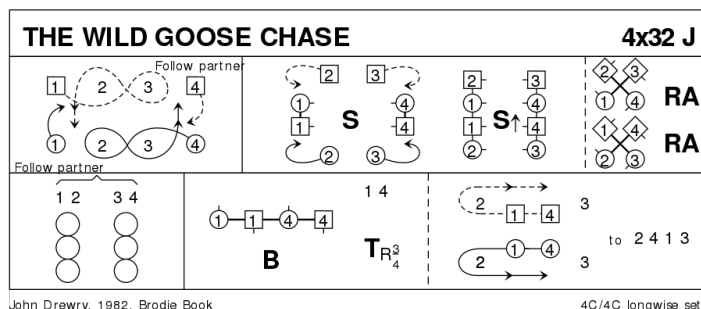

11 THE ARCTIC CIRCLE R64 · 4S

John Drewry: *New Dances by John Drewry 2005* · Crib: *MiniCribs* · Diagram: *Keith Rose's Diagrams*

- 1-8** All circle 8H round & back
- 9-16** 1M+3L also 1L+3M dance 1/2 Fig of 8 round 2s/4s, 1/2 turn & twirl back to place, finishing facing out
- 17-24** 1M & 3M turn corner RH **while** partners turn corner LH, all set to partner & turn 2H (skip change of step)
- 25-40** 2s & 4s repeat bars 9-24
- 41-48** All Ladies dance RH across 1/2 way, dance round opp Man LSh & dance RH across 1/2 way back to place
- 49-56** All Men dance LH across 1/2 way, dance round opp Lady RSh & dance LH across 1/2 way back to place
- 57-64** All promenaded round anticlockwise

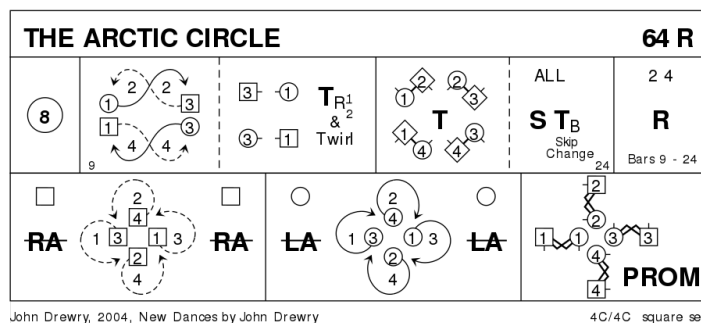

12 THE CHAIN WALK S32 · 3/3L

Roy Goldring: *14 Social Dances for 2000* · Crib: *MiniCribs*

- 1-8** 1M+3L pass LSh to face others partner & 1/2 reel of 4 on diagonal, 3M+1L chase round set clockwise into ptnrs pl **while** 1M+3L loop to ptnr's pl
- 9-16** 1s+2s RH across, 1M casts below 3L place & up to 2L place **while** 1L dances parallel path down middle, round 3M pl & to 2M pl (2s step up)
- 17-24** 2s+1s+3s Grand Chain
- 25-32** 2s+1s LH across, 1s+3s lead up to top, cross & cast on own sides. 2 3 1

13 THE ELUSIVE MUSE J32 · 3/3L

Tim Wilson: Measures of Pleasure · Crib: MiniCribbs · Diagram: Keith Rose's Diagrams

- 1-8** 1L dances RSh round prtnr to face 2L, 1s (1L leads) dance 1/2 Tandem reel of 3 across with 2s (LSh to 2L) ending 2s to top & 1s facing down
- 9-16** 1s dance down (4 bars), Lady turns under Mans arm & dance up to face 3L
- 17-24** 1s (1L leads) dance 1/2 Tandem reel of 3 across with 3s (RSh to 3L), 1s dance up to top & cast to 2nd place opposite sides
- 25-32** 2s+1s+3s Set+Link for 3 twice to end 3 1 2

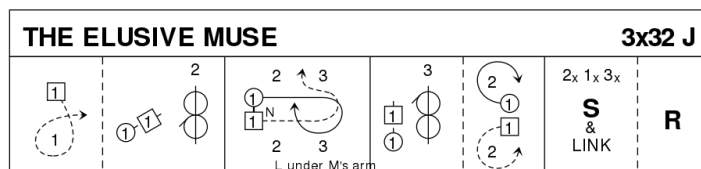

Tim Wilson, 2003, Measures of Pleasure, www.rscds-sf.org/resources/dances 3C/3C longwise set.

14 PETRONELLA R32 · 2/4L

RSCDS I 1 · Crib: MiniCribbs · Diagram: Keith Rose's Diagrams

- 1-16** 1s dance full petronella back to places
- 17-24** 1s lead down the middle & back again
- 25-32** 1s+2s dance Poussette

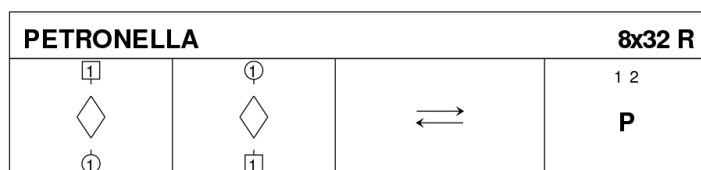

Gow, 1820, RSCDS Book 1.1

2C/4C longwise set.